



CODO 90° Long Radius

Normas de Diseño :
ANSI / ASME B16.9

Material:

Acero A234 WPB

Cédula:

STD, SCH 40, XS, SCH 80,
SCH 160

Espesor Mínimo:

-12.5% del valor nominal

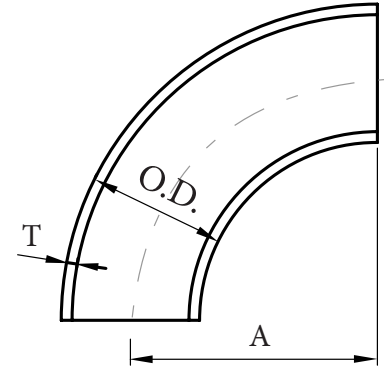

Unidad: Milímetros (mm)

MEDIDA	DIÁMETRO EXTERIOR (OD)	ESPESOR DE PARED (T)					CENTRO A FINAL (A)	PESO APROXIMADO (Kg)				
		STD	SCH 40	XS	SCH 80	SCH 160		STD	SCH 40	XS	SCH 80	SCH 160
1/2"	21.3	2.8	2.8	3.7	3.7	4.8	38.1	0.08	0.08	0.10	0.10	-
3/4"	26.7	2.9	2.9	3.9	3.9	5.6	28.4	0.11	0.11	0.14	0.14	-
1"	33.5	3.4	3.4	4.5	4.5	6.4	38.1	0.16	0.16	0.20	0.20	0.25
1 1/4"	42.2	3.6	3.6	4.9	4.9	6.4	47.8	0.26	0.26	0.35	0.35	0.42
1 1/2"	48.3	3.7	3.7	3.7	3.7	7.1	51	0.37	0.37	0.50	0.50	0.65
2"	60.5	3.9	3.9	5.5	5.5	8.7	76.2	0.66	0.66	0.90	0.90	1.33
2 1/2"	73.2	5.2	5.2	7.0	7.0	9.5	95.3	1.37	1.37	1.79	1.79	2.33
3"	88.9	5.5	5.5	7.6	7.6	11.1	114.3	2.04	2.04	2.74	2.74	3.83
4"	114.3	6.0	6.0	8.6	8.6	13.5	152.4	3.84	3.84	5.36	5.36	8.02
5"	141.2	6.6	6.6	9.5	9.5	15.9	190.5	6.48	6.48	9.13	9.13	14.7
6"	168.1	7.1	7.1	11.0	11.0	18.3	228.6	9.94	9.94	15.0	15.0	24.2
8"	218.9	8.2	8.2	12.7	12.7	23.0	304.8	20.1	20.1	30.5	30.5	53.2
10"	273.1	9.3	9.3	12.7	15.0	28.6	381.0	35.4	35.4	48.8	57.0	103
12"	323.9	9.5	10.3	12.7	17.5	33.3	457.2	53.1	57.0	70.0	94.0	171
14"	355.9	9.5	11.1	12.7	19.1	35.7	533.4	68.1	79.1	90.0	133	236
16"	406.4	9.5	12.7	12.7	21.4	40.4	609.6	89.3	118	118	195	350
18"	457.2	9.5	14.3	12.7	23.8	45.2	685.8	113	169	150	275	495
20"	508.0	9.5	15.0	12.7	26.1	50.0	762.0	140	220	186	373	676
22"	558.8	9.5	-	12.7	28.6	54.0	838.2	170	-	225	493	886
24"	609.6	9.5	17.5	12.7	31.0	59.5	914.4	202	366	269	636	1160