

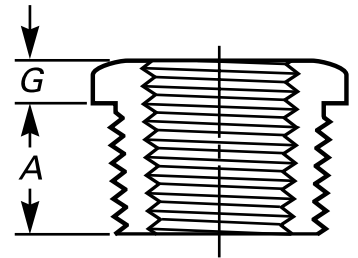

\* Reference photo

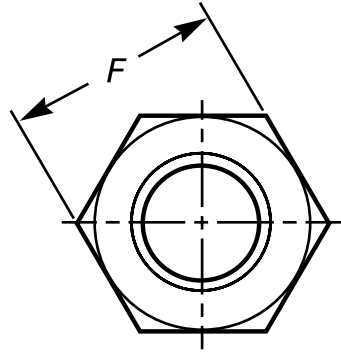

**Design:** ANSI B16.11  
**Threaded:** NPT ANSI B1.20.1  
**Material:** Forged Steel ASTM A105  
**Class:** 3000/6000  
**Correlation:**  
 Schedule 160 / Wall Designation XXS

**Units:** Millimeters (mm)

Nominal Pipe Size		Min. Length A	Nominal Width Flats, F	Min. Hex Height, G	Approx. Weight (kg)
inch	mm				
1/8"	6	10	11	-	0.01
1/4"	8	11	16	3	0.01
3/8"	10	13	18	4	0.02
1/2"	15	14	22	5	0.03
3/4"	20	16	27	6	0.05
1"	25	19	36	6	0.10
1 1/4"	32	21	46	7	0.17
1 1/2"	40	21	50	8	0.17
2"	50	22	65	9	0.35
2 1/2"	65	27	75	10	0.59
3"	80	28	90	10	1.71
4"	100	32	115	13	3.32

\* Note : Dimensions, design and materials are subject to change without notice.

MAC EDITIONS - MMXXIV

