

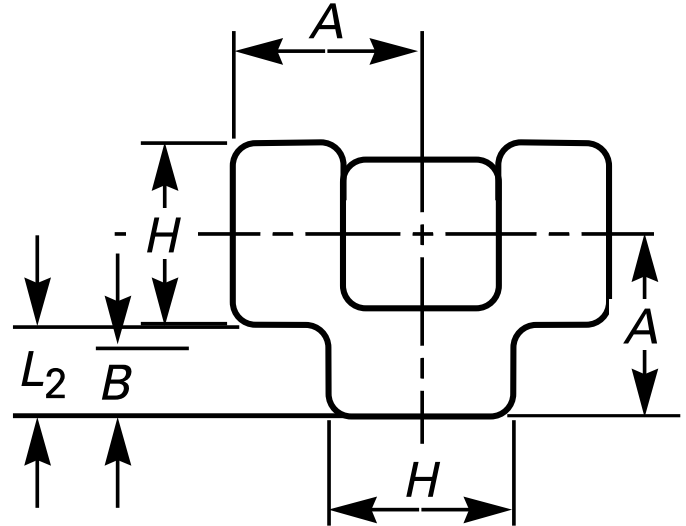

* Reference photo



Design: ANSI B16.11
Threaded: NPT ANSI B1.20.1
Material: Forged Steel ASTM A105
Class: 3000
Correlation: Schedule 160

Units: Millimeters (mm)

Nominal Pipe Size inch	Center-to-End, A	Outside Diameter of Band, H	Min. Wall Thickness, G	Min. Length of Thread		Approx. Weight kg
				B	L2	
1/8"	21	22	3.18	6.4	6.7	0.16
1/4"	25	25	3.30	8.1	10.2	0.21
3/8"	28	33	3.51	9.1	10.4	0.35
1/2"	33	38	4.09	10.9	13.6	0.59
3/4"	38	46	4.32	12.7	13.9	0.86
1"	44	56	4.98	14.7	17.3	1.40
1 1/4"	51	62	5.28	17.0	18.0	1.69
1 1/2"	60	75	5.56	17.8	18.4	3.17
2"	64	84	7.14	19.0	19.2	3.46
2 1/2"	83	102	7.65	23.6	28.9	6.65
3"	95	121	8.84	25.9	30.5	10.27
4"	114	152	11.18	27.7	33.0	18.18

* Note : Dimensions, design and materials are subject to change without notice.

MAC EDITIONS - MMXXIV

