

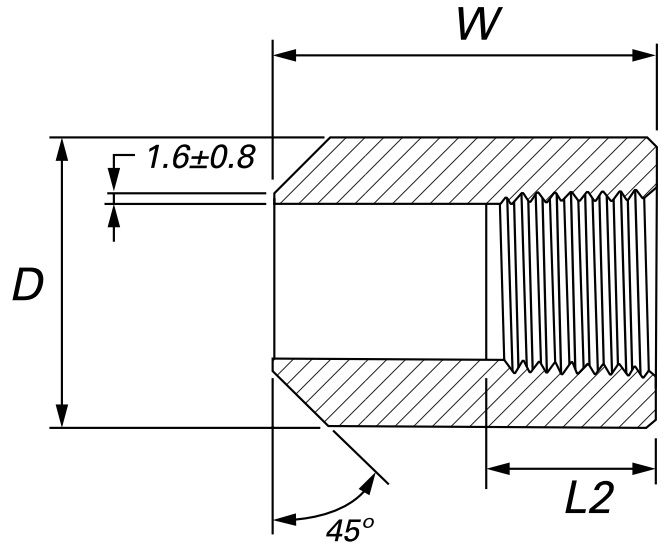

* Reference photo



Design: ANSI B16.11
Threaded: NPT ANSI B1.20.1
Material: Forged Steel ASTM A105
Class: 3000
Correlation: Schedule 160

Units: Millimeters (mm)

Nominal Pipe Size		D	W	L2 (Min.)	Approx. Weight
inch	mm				kg
1/4"	8	22.1	39.9	10.0	0.23
3/8"	10	25.9	50.0	10.5	0.29
1/2"	15	34.0	50.0	13.5	0.37
3/4"	20	39.1	50.0	14.0	0.50
1"	25	48.0	50.0	17.5	0.80
1 1/4"	32	59.9	50.0	18.0	0.90
1 1/2"	40	65.0	50.0	18.5	1.29
2"	50	80.0	59.0	19.0	1.78

MAC EDITIONS - MMXXIV

* Note : Dimensions, design and materials are subject to change without notice.

