

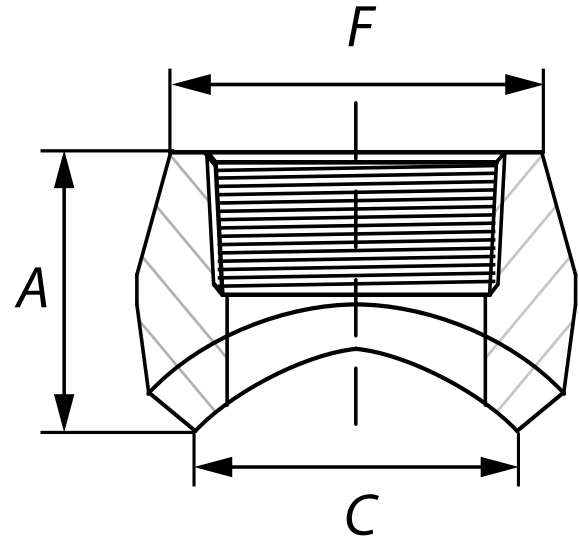

* Reference photo



Design: MSS-SP 97
Threaded: NPT ANSI B1.20.1
Material: Forged Steel ASTM A105
Class: 3000
Correlation: Schedule 160

Units: Millimeters (mm)

Nominal Pipe Size		A	C	F	Approx. Weight
inch	mm				kg
1/8"	6	19.0	13.7	17.3	0.05
1/4"	8	19.0	13.7	22.0	0.05
3/8"	10	21.0	17.1	25.8	0.09
1/2"	15	25.0	21.3	31.3	0.07
3/4"	20	27.0	26.7	37.1	0.11
1"	25	33.0	33.4	45.5	0.20
1 1/4"	32	33.0	42.2	54.9	0.32
1 1/2"	40	35.0	48.3	61.6	0.41
2"	50	38.0	60.3	75.3	0.63
2 1/2"	65	46.0	73.0	91.7	1.13
3"	76.2	51.0	88.9	109.1	1.95
3 1/2"	88.9	54.0	-	-	2.04
4"	100	57.0	114.3	137.2	3.08
5"	125	61.9	-	-	4.17
6"	150	69.85	-	-	7.12

* Note : Dimensions, design and materials are subject to change without notice.

MAC EDITIONS - MMXXIV

