

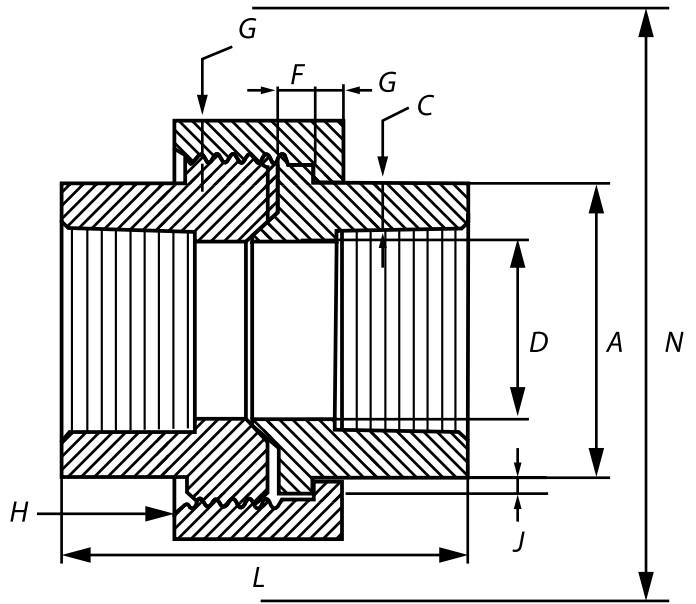

* Reference photo



Design: MSS-SP-83
Threaded: NPT ANSI B1.20.1
Material: Forged Steel ASTM A105
Class: 3000
Correlation: Schedule 160

Units: Millimeters (mm)

Nominal Pipe Size		Pipe End	Wall	Water Way Bore	Male Flange	Nut	Threads Per 25.4 mm	Bearing	Length Assem. Nom.	Clear Assem. Nut	Approx. Weight
inch	mm	Min. A	Min. C	D	Min. F	Min. G	Max. H	Min. J	L	N	kg
1/8"	6	14.7	2.41	8.43 6.43	3.18	3.18	16	1.24	41.4	50.8	0.19
1/4"	8	19.0	3.02	11.13 9.45	3.18	3.18	16	1.24	41.4	50.8	0.17
3/8"	10	22.9	3.20	14.27 13.51	3.43	3.43	14	1.37	46.0	55.9	0.24
1/2"	15	27.7	3.73	17.86 17.07	3.68	3.68	14	1.50	49.0	58.4	0.36
3/4"	20	33.5	3.91	23.01 21.39	4.06	4.06	11	1.68	56.9	66.0	0.57
1"	25	41.4	4.55	28.98 27.74	4.57	4.45	11	1.85	62.0	78.7	0.82
1 1/4"	32	50.5	4.85	37.69 35.36	5.33	5.21	11	2.13	71.1	94.0	1.31
1 1/2"	40	57.2	5.08	43.54 41.20	5.84	5.59	10	2.31	76.5	111.8	1.65
2"	50	70.1	5.54	55.58 52.12	6.60	6.35	10	2.69	86.1	132.1	2.63
2 1/2"	65	85.3	7.01	66.27 64.31	7.49	7.11	8	3.07	102.4	149.9	3.98
3"	80	102.4	7.62	88.25 77.27	8.26	8.00	8	3.53	109.0	175.3	5.89
4"	100	-	-	-	-	-	-	-	-	-	12.00

* Note : Dimensions, design and materials are subject to change without notice.

MAC EDITIONS - MMXXIV

