

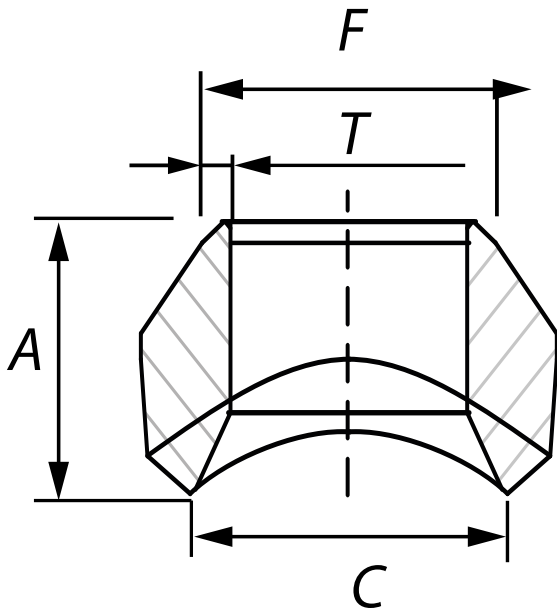

* Reference photo

Design: MSS-SP-97-2001
Material: Forged Steel ASTM A105
Class: 3000
Correlation:
 Schedule 160



Size		A	C	F	T	Approx. Weighth
inch	mm					kg
1/8"	6	16.0	13.7	10.3	1.73	0.05
1/4"	8	16.0	13.7	13.7	2.24	0.05
3/8"	10	19.0	17.1	17.1	2.31	0.07
1/2"	15	19.0	21.3	21.3	2.77	0.09
3/4"	20	22.0	26.7	26.7	2.87	0.11
1"	25	27.0	33.4	33.4	3.38	0.23
1 1/4"	32	32.0	42.2	42.2	3.56	0.36
1 1/2"	40	33.0	48.3	48.3	3.68	0.45
2"	50	38.0	60.3	60.3	3.91	0.79
2 1/2"	65	41.0	73.0	73.0	5.16	1.13
3"	80	44.0	88.9	88.9	5.49	1.81
3 1/2"	88.9	50.0	-	-	-	2.49
4"	100	51.0	114.3	114.3	6.02	2.86
5"	125	57.0	141.3	141.3	6.55	4.65
6"	150	60.0	168.3	168.3	7.11	5.44
8"	200	70.0	219.3	219.3	8.11	10.43
10"	250	78.0	273.1	273.1	9.27	16.33
12"	300	86.0	323.9	323.9	9.53	26.76
14"	350	89.0	355.6	355.6	9.53	29.93
16"	400	94.0	406.4	406.4	9.53	34.01
18"	450	97.0	457.2	457.2	9.53	43.99
20"	500	102.0	508.0	508.0	9.53	53.51
24"	600	116.0	609.6	609.6	9.53	99.77

Units: Millimeters (mm)

* Note : Dimensions, design and materials are subject to change without notice.