



TEE REDUCCIÓN

Normas de Diseño :
ANSI / ASME B 16.9

Material:

Acero A234 WPB

Cédula:

STD, SCH 40, XS, SCH 80,
SCH 160

Espesor Mínimo:

-12.5% del valor nominal

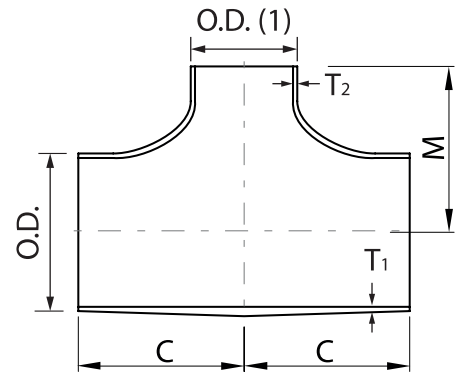

Unidad: Milímetros (mm)

MEDIDA	DIÁMETRO EXTERIOR		ESPESOR DE PARED T1					ESPESOR DE PARED T2					CENTRO A FINAL		PESO APROX (Kg)				
	O.D.	O.D. (1)	STD	SCH 40	XS	SCH 80	SCH 160	STD	SCH 40	XS	SCH 80	SCH 160	C	M	STD	SCH 40	XS	SCH 80	SCH 160
3/4" x 1/2"	26.7	21.3	2.87	2.87	3.91	3.91	5.56	2.77	2.77	3.73	3.73	4.78	28.4	28.4	0.12	0.12	0.16	0.16	-
1" x 3/4"	33.4	26.7	3.38	3.38	4.55	4.55	6.35	2.87	2.87	3.91	3.91	5.56	38.1	38.1	0.24	0.24	0.30	0.30	-
1" x 1/2"	33.4	21.3	3.38	3.38	4.55	4.55	6.35	2.77	2.77	3.73	3.73	4.78	38.1	38.1	0.23	0.23	0.29	0.29	-
1 1/4" x 1"	42.2	33.4	3.56	3.56	4.85	4.85	6.35	3.38	3.38	4.55	4.55	6.35	47.8	47.8	0.43	0.43	0.56	0.56	-
1 1/4" x 3/4"	42.2	26.7	3.56	3.56	4.85	4.85	6.35	2.87	2.87	3.91	3.91	5.56	47.8	47.8	0.40	0.40	0.53	0.53	-
1 1/2" x 1 1/4"	48.3	42.2	3.68	3.68	5.08	5.08	7.14	3.56	3.56	4.85	4.85	6.35	57.2	57.2	0.59	0.59	0.78	0.78	-
1 1/2" x 1"	48.3	33.4	3.68	3.68	5.08	5.08	7.14	3.38	3.38	4.55	4.55	6.35	57.2	57.2	0.56	0.56	0.74	0.74	-
1 1/2" x 3/4"	48.3	26.7	3.68	3.68	5.08	5.08	7.14	2.87	2.87	3.91	3.91	5.56	57.2	57.2	0.53	0.53	0.70	0.70	-
2" x 1 1/2"	60.3	48.3	3.91	3.91	5.54	5.54	8.74	3.68	3.68	5.08	5.08	7.14	63.5	60.5	0.82	0.82	1.11	1.11	-
2" x 1 1/4"	60.3	42.2	3.91	3.91	5.54	5.54	8.74	3.56	3.56	4.85	4.85	6.35	63.5	57.2	0.79	0.79	1.09	1.09	1.07
2" x 1"	60.3	33.4	3.91	3.91	5.54	5.54	8.74	3.38	3.38	4.55	4.55	6.35	63.5	50.8	0.75	0.75	1.01	1.01	1.01
2 1/2" x 2"	73.0	60.3	5.16	5.16	7.01	7.01	9.53	3.91	3.91	5.54	5.54	8.74	76.2	69.9	1.56	1.56	2.06	2.06	3.56
2 1/2" x 1 1/2"	73.0	48.3	5.16	5.16	7.01	7.01	9.53	3.68	3.68	5.08	5.08	7.14	76.2	66.5	1.51	1.51	1.98	1.98	3.40
2 1/2" x 1 1/4"	73.0	42.2	5.16	5.16	7.01	7.01	9.53	3.56	3.56	4.85	4.85	6.35	76.2	63.5	1.48	1.48	1.94	1.94	-
3" x 2 1/2"	88.9	73.0	5.49	5.49	7.62	7.62	11.13	5.16	5.16	7.01	7.01	9.53	85.9	82.6	2.29	2.29	3.07	3.07	5.45
3" x 2"	88.9	60.3	5.49	5.49	7.62	7.62	11.13	3.91	3.91	5.54	5.54	8.74	85.9	76.2	2.12	2.12	2.85	2.85	5.17
3" x 1 1/2"	88.9	48.3	5.49	5.49	7.62	7.62	11.13	3.68	3.68	5.08	5.08	7.14	85.9	73.2	2.06	2.06	2.77	2.77	-
4" x 3"	114.3	88.9	6.02	6.02	8.56	8.56	13.49	5.49	5.49	7.62	7.62	11.13	104.6	98.6	3.83	3.83	5.33	5.33	9.05
4" x 2 1/2"	114.3	73.0	6.02	6.02	8.56	8.56	13.49	5.16	5.16	7.01	7.01	9.53	104.6	95.3	3.71	3.71	5.15	5.15	7.74
4" x 2"	114.3	60.3	6.02	6.02	8.56	8.56	13.49	3.91	3.91	5.54	5.54	8.74	104.6	88.9	3.53	3.53	4.94	4.94	7.30



TEE REDUCCIÓN

MEDIDA	DIÁMETRO EXTERIOR		ESPESOR DE PARED T1					ESPESOR DE PARED T2					CENTRO A FINAL		PESO APROX (Kg)				
	O.D.	O.D. (I)	SCH STD	SCH 40	SCH XS	SCH 80	SCH 160	SCH STD	SCH 40	SCH XS	SCH 80	SCH 160	C	M	SCH STD	SCH 40	SCH XS	SCH 80	SCH 160
5" x 4"	141.3	114.3	6.55	6.55	9.53	9.53	15.88	6.02	6.02	8.56	8.56	13.49	124.0	117.3	6.13	6.13	8.63	8.63	15.3
5" x 3"	141.3	88.9	6.55	6.55	9.53	9.53	15.88	5.49	5.49	7.62	7.62	11.13	124.0	111.3	5.83	5.83	8.19	8.19	14.7
5" x 2 1/2"	141.3	73.0	6.55	6.55	9.53	9.53	15.88	5.16	5.16	7.01	7.01	9.53	124.0	108.0	5.71	5.71	8.01	8.01	14.3
6" x 5"	168.3	141.3	7.11	7.11	10.97	10.97	18.26	6.55	6.55	9.53	9.53	15.88	142.7	136.7	9.08	9.08	13.5	13.5	24.3
6" x 4"	168.3	114.3	7.11	7.11	10.97	10.97	18.26	6.02	6.02	8.56	8.56	13.49	142.7	130.0	8.67	8.67	13.0	13.0	23.2
6" x 3"	168.3	88.9	7.11	7.11	10.97	10.97	18.26	5.49	5.49	7.62	7.62	11.13	142.7	124.0	8.38	8.38	12.6	12.6	22.5
8" x 6"	219.1	168.3	8.18	8.18	12.70	12.70	23.01	7.11	7.11	10.97	10.97	18.26	177.8	168.1	16.6	16.6	25.2	25.2	47.6
8" x 5"	219.1	141.3	8.18	8.18	12.70	12.70	23.01	6.55	6.55	9.53	9.53	15.88	177.8	162.1	16.1	16.1	24.3	24.3	46.1
8" x 4"	219.1	114.3	8.18	8.18	12.70	12.70	23.01	6.02	6.02	8.56	8.56	13.49	177.8	155.4	15.7	15.7	23.7	23.7	45.0
10" x 8"	273.1	219.1	9.27	9.27	12.70	15.09	28.58	8.18	8.18	12.70	12.70	23.01	215.9	203.2	28.5	28.5	58.4	65.80	89.7
10" x 6"	273.1	168.3	9.27	9.27	12.70	15.09	28.58	7.11	7.11	10.97	10.97	18.26	215.9	193.5	27.2	27.2	54.5	59.70	80.9
10" x 5"	273.1	141.3	9.27	9.27	12.70	15.09	28.58	6.55	6.55	9.53	9.53	15.88	215.9	190.5	26.8	26.8	53.5	59.70	79.6
12" x 10"	323.9	273.1	9.53	10.31	12.70	17.48	33.32	9.27	9.27	12.70	15.09	28.58	254.0	241.3	59	41.6	78.0	106.20	146
12" x 8"	323.9	219.1	9.53	10.31	12.70	17.48	33.32	8.18	8.18	12.70	12.70	23.01	254.0	228.6	47	39.7	74.80	85.40	139
12" x 6"	323.9	168.3	9.53	10.31	12.70	17.48	33.32	7.11	7.11	10.97	10.97	18.26	254.0	218.9	47	38.4	74.80	85.40	136
14" x 12"	355.6	323.9	9.53	11.13	12.70	19.05	35.71	9.53	10.31	9.53	17.48	33.32	279.4	269.7	68	60.1	108.90	162.30	192
14" x 10"	355.6	273.1	9.53	11.13	12.70	19.05	35.71	9.27	9.27	9.27	15.09	28.58	279.4	257.0	67	49.9	103.80	108	184
14" x 8"	355.6	219.1	9.53	11.13	12.70	19.05	35.71	9.27	8.18	12.70	12.70	23.01	279.4	247.7	66	48.2	103.80	141.90	178
16" x 14"	406.4	355.6	9.53	12.70	12.70	21.44	40.49	9.53	11.13	12.70	19.05	35.71	304.8	304.8	99	86.1	135.50	158	280
16" x 12"	406.4	323.9	9.53	12.70	12.70	21.44	40.49	9.53	10.31	12.70	17.48	33.32	304.8	295.1	95	83.6	134.00	152	263
16" x 10"	406.4	273.1	9.53	12.70	12.70	21.44	40.49	9.27	9.27	12.70	15.09	28.58	304.8	282.4	88	81.2	130.50	147	255
18" x 16"	457.2	406.4	9.53	14.27	12.70	23.83	45.24	9.53	12.70	12.70	21.44	40.49	342.9	330.2	127	135	126.8	228	416
18" x 14"	457.2	355.6	9.53	14.27	12.70	23.83	45.24	9.53	11.13	12.70	19.05	35.71	342.9	330.2	122	132	124.9	223	375
18" x 12"	457.2	323.9	9.53	14.27	12.70	23.83	45.24	9.53	10.31	12.70	17.48	33.32	342.9	320.5	117	128	122.6	217	368
20" x 18"	508.0	457.2	9.53	15.09	12.70	26.19	50.01	9.53	14.27	12.70	23.83	45.24	381.0	368.3	161	188	157.5	306	528
20" x 16"	508.0	406.4	9.53	15.09	12.70	26.19	50.01	9.53	12.70	12.70	21.44	40.49	381.0	355.6	155	181	153.6	294	508
20" x 14"	508.0	355.6	9.53	15.09	12.70	26.19	50.01	9.53	11.13	12.70	19.05	35.71	381.0	355.6	149	178	151.8	289	491
22" x 20"	558.8	508.0	9.53	-	12.70	28.58	53.98	9.53	15.09	12.70	26.19	50.01	419.1	406.4	201	-	191.6	386	740
22" x 18"	558.8	457.2	9.53	-	12.70	28.58	53.98	9.53	14.27	12.70	23.83	45.24	419.1	393.7	195	-	187.3	373	696
22" x 16"	558.8	406.4	9.53	-	12.70	28.58	53.98	9.53	12.70	12.70	21.44	40.49	419.1	381.0	187	-	183.2	354	656
24" x 22"	609.6	558.8	9.53	17.48	12.70	30.96	59.54	9.53	-	12.70	28.58	53.98	431.8	431.8	240	-	215.6	503	922
24" x 20"	609.6	508.0	9.53	17.48	12.70	30.96	59.54	9.53	15.09	12.70	26.19	50.01	431.8	431.8	230	268	210.8	467	843
24" x 18"	609.6	457.2	9.53	17.48	12.70	30.96	59.54	9.53	14.27	12.70	23.83	45.24	431.8	419.1	222	249	206.6	418	769

* Fotos y medidas referenciales, sujetas a cambios sin previo aviso por parte del proveedor o fabricante.