

Normas de Diseño:

Roscado NPT ANSI B1.20.1

Material: Acero Inoxidable ASTM A351
CF8 (304) y CF8M (316)

Presión de Trabajo:

300 PSI @ -28°C a 38°C / 150 SWP

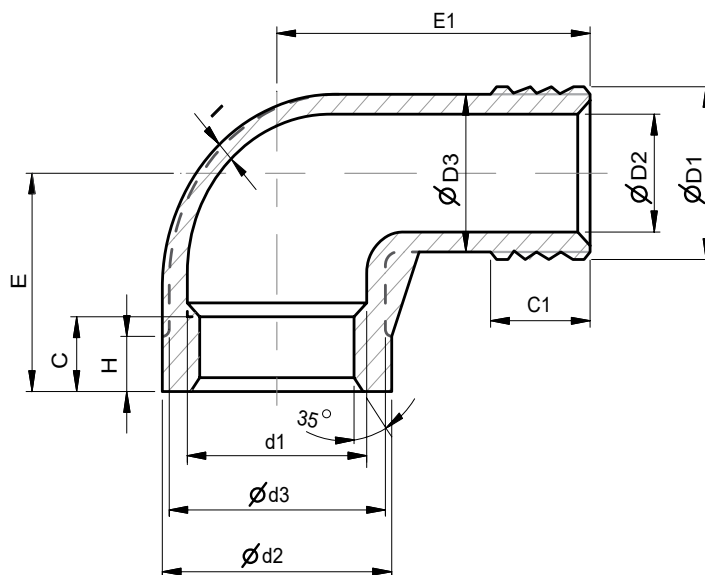

*Extremos roscados macho-hembra (M/H)

* Male-female threaded ends (M/F)

Unidad: Pulgadas (inch)

Medida	d1	d2	d3	C	E	H	D1	D2	D3	C1	E1	I	Peso (Kg)
1/8"	1/8"	0.59	0.47	0.28	0.71	0.20	1/8"	0.20	0.35	0.31	1.02	0.08	0.04
1/4"	1/4"	0.71	0.59	0.41	0.87	0.20	1/4"	0.24	0.47	0.43	1.22	0.08	0.06
3/8"	3/8"	0.89	0.79	0.41	0.87	0.24	3/8"	0.35	0.55	0.43	1.54	0.08	0.09
1/2"	1/2"	1.10	1.02	0.39	1.06	0.31	1/2"	0.55	0.75	0.51	1.61	0.08	0.15
3/4"	3/4"	1.42	1.30	0.47	1.30	0.35	3/4"	0.79	0.98	0.51	1.85	0.08	0.23
1"	1"	1.77	1.65	0.55	1.46	0.35	1"	0.98	1.22	0.73	2.09	0.08	0.39
1 1/4"	1 1/4"	2.05	1.97	0.67	1.73	0.43	1 1/4"	1.30	1.56	0.75	2.48	0.10	0.58
1 1/2"	1 1/2"	2.36	2.24	0.67	1.85	0.43	1 1/2"	1.57	1.83	0.75	2.72	0.10	0.72
2"	2"	2.87	2.72	0.71	2.32	0.51	2"	1.97	2.24	0.85	3.15	0.10	1.08
2 1/2"	2 1/2"	3.54	3.39	0.91	2.60	0.59	2 1/2"	2.24	2.60	0.94	4.13	0.16	2.61
3"	3"	4.17	3.98	0.94	3.09	0.65	3"	2.91	3.19	1.14	4.45	0.16	3.56
4"	4"	5.14	5.04	1.02	3.86	0.77	4"	3.82	4.17	1.34	5.12	0.16	6.91