



* Reference photo

Steel Body Forged Steel ASTM A105
 Ball: SS 316
 Seats of RPTFE or POLYFILL (PTFE + 15% de Graphite | Black)
 Thread ends NPT ANSI/ASME B1.20.1
 Memoryseal seating technology
 One piece body. Passage reduced.
 Maximum Working Pressure:
 1/4" - 1" 2000 PSIG
 1 1/4" - 2" 1500 PSIG
 Maximum temperature operation:
 RPTFE -20°C (-4°F) to 150°C (302°F)
 POLYFILL -28°C (-20°F) to 240°C (464°F)
 Tests according to API 598

MATERIALS

	PART NAME	MATERIAL
1	BODY	ASTM A105
2	RETAINER	ASTM A105
3	BALL	ASTM A351 CF8M
4	STEM	ASTM A276-316
5	GLAND RING	ASTM A105
6	BALL SEAT	POLYFILL or RPTFE
7	THRUST WASHER	PTFE
8	PACKING	PTFE
9	SPRING WASHER	AISI 304
10	STEM NUT	AISI 304
11	HANDLE	AISI 304
12	HANDLE SLEEVE	PVC

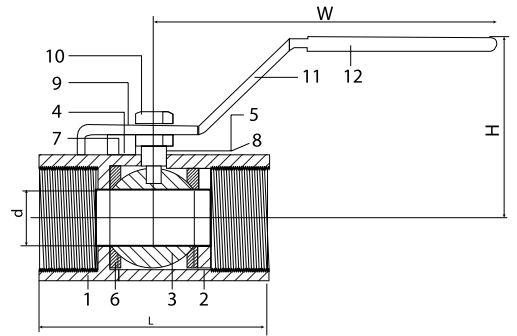

Fiorella Representaciones S.A.C.
 Importador y distribuidor autorizado de
 válvulas REX para Perú y para su exportación.

PRESSURE TEMPERATURE RATINGS

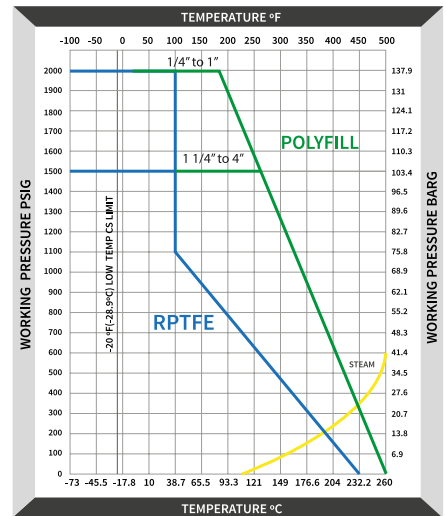

DIMENSIONS (mm)

SIZE	d	L	H	W	WEIGHT (Kg)
1/4"	5.1	1.70	43.2	50.8	0.2
3/8"	7.1	1.86	47.2	86.4	0.2
1/2"	8.9	2.43	61.7	101.6	0.8
3/4"	12.4	2.75	69.9	101.6	1.2
1"	15.0	3.38	85.9	127.0	1.8
1 1/4"	20.1	3.69	93.7	152.4	2.5
1 1/2"	24.9	4.00	101.6	152.4	3.5
2"	32.0	4.50	114.3	152.4	4.5

* Note : Dimensions, design and materials are subject to change without notice. Approximate weights.

MAC EDITIONS - MMXXIII

