

* Reference photo

Steel Body type ASTM A216 WCB
 Ball: SS 316 (Optional SS 304)
 Seats of POLYFILL
 Thread ends NPT ANSI/ASME B1.20.1
 Memoryseal seating technology
 Three piece body. Full Passage
 Blow-Out-Proof Stem
 Mounting Pad ISO 5211
 Locking Device
 Maximum Working Pressure: 1000 PSIG
 Maximum temperature operation:
 POLYFILL -28°C (-20°F) to 240°C (464°F)
 Tests according to API 598

MATERIALS

	PART NAME	MATERIAL
1	BODY	ASTM A216 WCB
2	CAP	ASTM A216 WCB
3	BALL	ASTM A351 CF8M
4	STEM	ASTM A276 Gr. 304
5	SEAT	POLYFILL
6	PACKING	PTFE
7	GLAND	SS304
8	END SEALS	PTFE
9	THRUST WASHER	PTFE
10	HANDLE	SS304
11	HANDLE NUT	SS304
12	SPRING WASHER	SS304
13	BOLTS	ASTM A193 Gr. B8
14	BOLT NUTS	ASTM A194 Gr. 8
15	BOLT WASHERS	SS304
16	HANDLE SLEEVE	VINYL GRIP
17	LOCKING PLATE	SS304

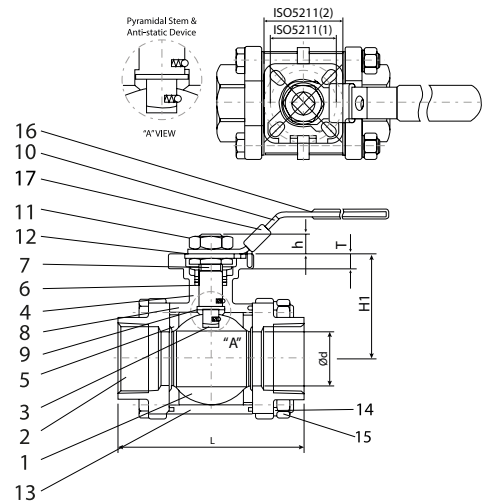

Fiorella Representaciones S.A.C.
 Importador y distribuidor autorizado de
 válvulas REX para Perú y para su exportación.

DIMENSIONS (mm)

SIZE	d	L	H1	H	T	ISO 5211	CV FACTOR	WEIGHT (Kg)
1/4"	14.1	65	7	40	7	F03 / F04	16	0.48
3/8"	17.6	65	8	40.5	7	F03 / F04	16	0.46
1/2"	15.0	71	9	42.5	9	F03 / F04	26	0.78
3/4"	20.0	85	9	46.5	9	F03 / F04	55	1.01
1"	25.4	95	12.0	59.5	9	F04 / F05	110	1.46
1 1/4"	32.0	111	12.0	63.0	9	F04 / F05	180	2.18
1 1/2"	40.0	121	16	79.0	13	F05 / F07	270	3.50
2"	50.8	140	16	86.9	13	F05 / F07	500	4.71

PRESSURE TEMPERATURE RATINGS

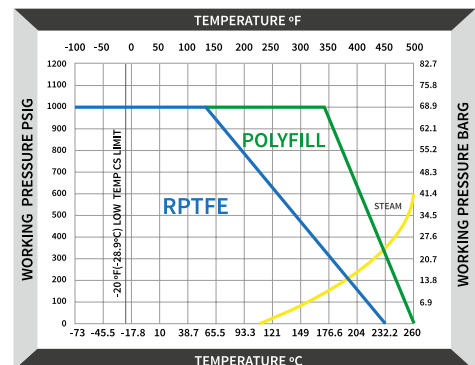

* Note : Dimensions, design and materials are subject to change without notice. Approximate weights.

