



\* Reference photo

Steel Body type ASTM A105  
 Ball: SS 316 (Optional SS 304)  
 Seats of RPTFE or POLYFILL  
 Thread ends NPT ANSI/ASME B1.20.1  
 Memoryseal seating technology  
 Two pieces body. Full Passage.  
 Blow-Out-Proof Stem  
 Maximum Working Pressure:  
 1/4" - 1" 2000 PSIG  
 1 1/4" - 4" 1500 PSIG  
 Maximum temperature operation:  
 RPTFE -20°C (-4°F) to 150°C (302°F)  
 POLYFILL -28°C (-20°F) to 240°C (464°F)  
 Tests according to API 598

### MATERIALS

	PART NAME	MATERIAL
1	BODY	ASTM A105
2	BALL	ASTM A351 CF8M
3	SEAT	RPTFE OR POLYFILL
4	GASKET	PTFE
5	CAP	ASTM A105
6	STEM	A276 - 316
7	THRUST WASHER	PTFE
8	ANTI-STATIC	SS304
9	HANDLE	SS+PVC
10	POSITION LOCATOR	Q235
11	NUTS	A194 2H
12	BELLEVILLE WASHER	SS301
13	PACKING GLAND	A276 304
14	PACKING	PTFE
15	STOPPER	A193 B7

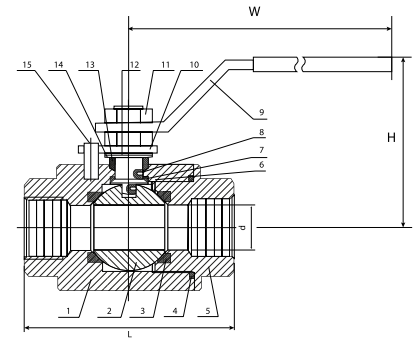

**Fiorella Representaciones S.A.C.**  
 Importador y distribuidor autorizado de  
 válvulas REX para Perú y para su exportación.

### PRESSURE TEMPERATURE RATINGS

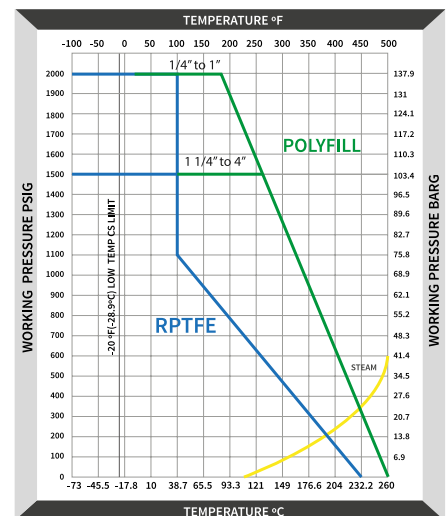

### DIMENSIONS (mm)

SIZE	d	L	H	W	WEIGHT (Kg)
1/4"	11.0	57.8	57.2	103	0.26
3/8"	12.5	57.8	57.2	103	0.24
1/2"	15.0	61.7	59.1	103	0.29
3/4"	20.0	70.1	62.6	103	0.58
1"	25.0	81.3	70.7	127	1.00
1 1/4"	32.0	96.0	76.2	127	1.70
1 1/2"	38.0	112.5	89.1	153	2.40
2"	50.8	126.0	98.2	193	3.64
2 1/2"	65.0	168.5	110.6	193	6.25
3"	80.0	191.4	124.0	279	10.42
4"	100.0	216.5	168.5	335	17.20

\* Note : Dimensions, design and materials are subject to change without notice. Approximate weights.

