

* Reference photo

DESIGN FEATURES:

- Pressure rating: 1000 PSIG (non-shock)
- Steam rating: 150 PSI WSP
- Investment cast body & cap
- Blow-out-proof stem adjustable stem
- Adjustable stem packing
- Stainless steel handle with vinyl grip and locking system
- Threaded NPT ANSI/ASME B1.20.1
- Test standard: API 598

MATERIAL LIST

	PART NAME	MATERIAL	QTY.
1	BODY	ASTM A351 Gr. CF8	1
2	CAP	ASTM A351 Gr. CF8	2
3	BALL	ASTM A351 Gr. CF8	1
4	STEM	ASTM A276 Gr. 304	1
5	SEAT	RPTFE (PTFE + 15% G/F)	2
6	PACKING	PTFE	1
7	GLAND	SS304	1
8	END SEALS	PTFE	2
9	THRUST WASHER	PTFE	1
10	HANDLE	STAINLESS STEEL	1
11	HANDLE NUT	SS304	1
12	SPRING WASHER	SS304	1
13	BOLTS	ASTM A193 Gr. B8	4-6
14	BOLT NUTS	ASTM 194 Gr. 8	4-6
15	BOLT WASHERS	SS304	4-6
16	HANDLE SLEEVE	VINYL GRIP	1
17	LOCKING PLATE	STAINLESS STEEL	1

DIMENSIONS (mm)

SIZE	d	L	D1	H	W1	h	CV Factor	WEIGHT (Kg)
1/4"	11.0	65	102	54	36	M5 X P0.8	6	0.290
3/8"	12.5	65	102	54	36	M5 X P0.8	12	0.261
1/2"	15.0	71	102	55	36	M5 X P0.8	19	0.360
3/4"	20.0	85	126	65	36	M5 X P0.8	37	0.610
1"	25.4	95	126	71	36	M5 X P0.8	64	0.825
1 1/4"	32.0	111	150	89	50	M6 X P1.0	103	1.438
1 1/2"	40.0	121	150	94	50	M6 X P1.0	143	1.753
2"	50.8	140	186	100	50	M6 X P1.0	360	3.098
2 1/2"	65.0	173	272	121	70	M8 X P1.25	440	6.100
3"	80.0	192	272	134	102	M10 X P1.5	520	9.120
4"	100.0	225	335	172	102	M10 X P1.5	820	19.525

Fiorella Representaciones S.A.C. Importador y distribuidor autorizado de válvulas SUN en territorio latinoamericano.

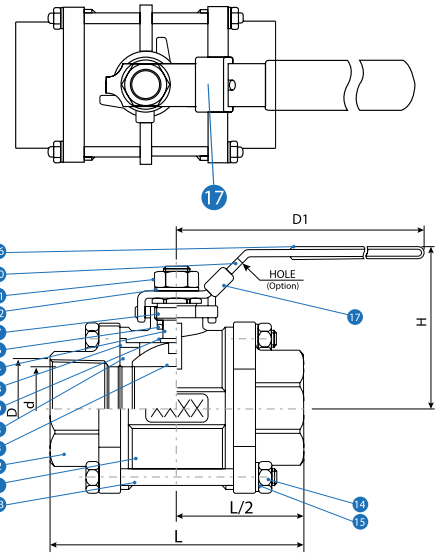

PRESSURE TEMPERATURE RATINGS

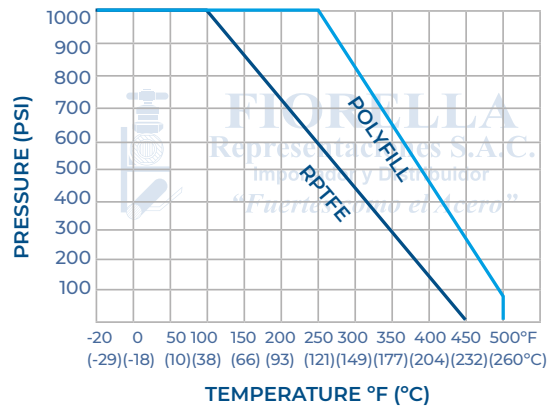

MAC EDITIONS - MMXXIII

* Note : Dimensions, design and materials are subject to change without notice.