



* Reference photo

DESIGN FEATURES:

Working pressure:
1/2"~1" 2000 PSIG - 1 1/4"~2" 1500 PSIG
Blow-out-proof stem
Adjustable stem packing
Handle with locking system
Threaded end NPT ANSI/ASME B1.20.1
Test standard: API 598

MATERIAL LIST

	PART NAME	MATERIAL	QTY.
1	BODY	ASTM A351 Gr. CF8M	1
2	CAP	ASTM A351 Gr. CF8M	2
3	BALL	ASTM A351 Gr. CF8M	1
4	STEM	ASTM A276 Gr. 316	1
5	SEAT	RPTFE	2
6	PACKING	PTFE	1
7	GLAND	SS316	1
8	END SEALS	PTFE	2
9	THRUST WASHER	PTFE	1
10	HANDLE	STAINLESS STEEL	1
11	HANDLE NUT	SS316	1
12	SPRING WASHER	SS316	1
13	BOLTS	ASTM A193 Gr. B8	4-6
14	BOLT NUTS	ASTM 194 Gr. 8	4-6
15	BOLT WASHERS	SS316	4-6
16	HANDLE SLEEVE	VINYL GRIP	1
17	LOCKING PLATE	STAINLESS STEEL	1

DIMENSIONS (mm)

SIZE	A	C	D	d	L	H1	h	S	T	ISO 5211	CV FACTOR	WEIGHT (Kg)
1/2"	10	29.1	21.7	15.0	73.5	42.1	9.0	9	9	F03/F04	26	0.78
3/4"	13	36.7	27.1	20.0	83.0	46.5	9.0	9	9	F03/F04	55	0.98
1"	13	46.0	33.8	25.4	99.0	59.0	11.5	11	9	F04/F05	110	1.43
1 1/4"	13	51.9	42.6	32.0	114.0	62.5	11.5	11	9	F04/F05	180	2.17
1 1/2"	13	59.3	48.7	40.0	128.0	79.0	16.0	14	13	F05/F07	270	3.28
2"	16	72.6	61.2	50.8	152.0	86.9	16.0	14	13	F07/F07	500	4.64

Fiorella Representaciones S.A.C. Importador y distribuidor autorizado de válvulas SUN en territorio latinoamericano.

PRESSURE TEMPERATURE RATINGS

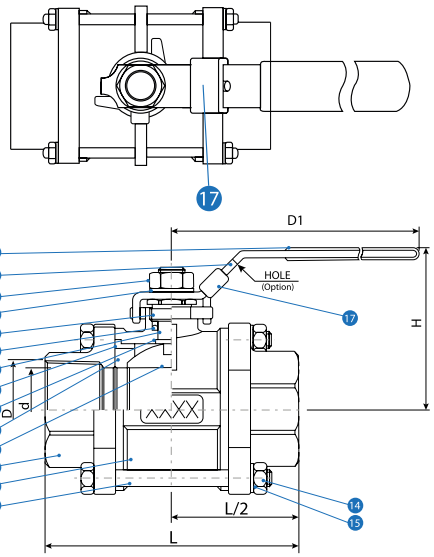
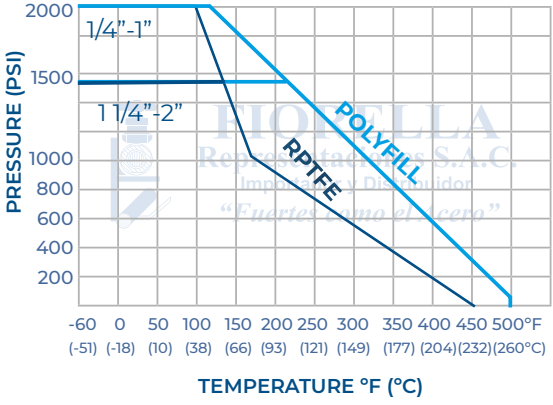

MAC EDITIONS - MMXXIII

* Note : Dimensions, design and materials are subject to change without notice.