



* Reference photo

DESIGN FEATURES:

- Pressure rating: 1000 CWP / PSIG (non-shock)
- Steam rating: 150 PSI WSP
- Investment cast body & cap
- Bottom-loaded, blow-out-proof stem
- Direct mounting ISO 5211 for actuators
- Stainless steel handle with vinyl grip
- Threaded end NPT ANSI/ANSI B1.20.1
- Test standard: API 598

MATERIAL LIST

	PART NAME	MATERIAL	QTY.
1	BODY	ASTM A351 Gr. CF8M	1
2	CAP	ASTM A351 Gr. CF8M	2
3	BALL	ASTM A351 Gr. CF8M	1
4	SEAT	RPTFE (PTFE + 15% G/F)	2
5	BOLT	ASTM A193 Gr. B8	4-6
6	GASKET	PTFE	2
7	THRUST WASHER	PTFE	1
8	STEM	ASTM A276 Gr. 304	1
9	PACKING	PTFE	1
10	RING	SS304	1
11	BELLEVEILLE WASHER	SS410	2
12	HANDLE NUT	SS304	2
13	STOPPER	SS304	1
14	LOCKING PLATE	STAINLESS STEEL	1
15	HANDLE	STAINLESS STEEL	1
16	HANDLE SLEEVE	VINYL GRIP	1
17	BOLT WASHER	SS304	4-6
18	BOLT NUT	ASTM A194 Gr. 8	4-6

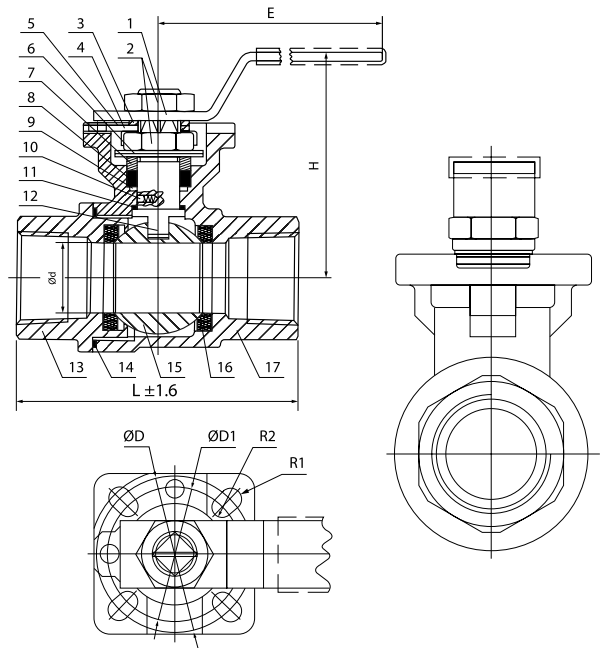

DIMENSIONS (mm)

SIZE	d	L	H	E	D	D1	R1	R2	CV	TQ (in/lbs)	ISO 5211	WEIGHT (Kg)
1/2"	15	62	64	110	42	36	3	3	13	60/7	F03/F04	0.3
3/4"	20	72	80	120	42	36	3	3	50	80/9	F03/F04	0.41
1"	25	84	93	145	50	42	3.5	3	93	130/15	F04/F05	0.7
1 1/4"	32	97	95	145	50	42	3.5	3	170	160/18	F04/F05	0.95
1 1/2"	38	104	126	160	70	50	4.5	3.5	250	200/23	F05/F07	1.5
2"	49	123	129	170	70	50	4.5	3.5	450	280/32	F05/F07	2.1
2 1/2"	65	145	148	230	102	70	5.5	4.5	750	500/57	F07/F10	4
3"	78	168	152	260	102	70	5.5	4.5	1300	650/73	F07/F10	4.7

Fiorella Representaciones S.A.C. Importador y distribuidor autorizado de válvulas SUN en territorio latinoamericano.

PRESSURE TEMPERATURE RATINGS

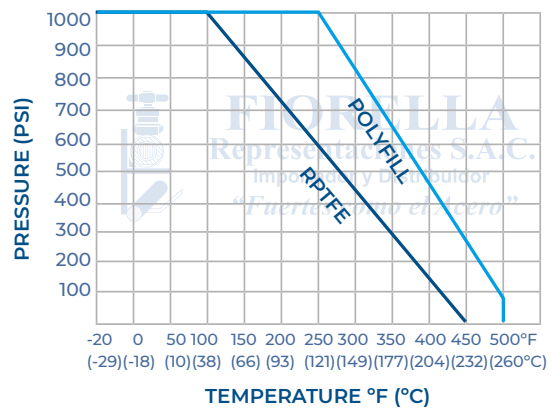

MAC - MMXXI

* Note : Dimensions, design and materials are subject to change without notice.