

DESIGN FEATURES:

Pressure rating: 200 PSIG (non-shock)
 Steam rating: 150 PSI WSP
 Investment cast body & bonnet
 Bottom-loaded, blow-out-proof stem
 Screwed bonnet
 Rising stem and wheel
 Threaded end NPT ANSI/ASME B1.20.1
 Test standard: API 598

* Reference photo



MATERIAL LIST

	PART NAME	MATERIAL	QTY.
1	NUT	SS304	1
2	HANDWHEEL	SS400	1
3	STEM	ASTM A276 Gr. 304	1
4	GLAND NUT	ASTM A351 Gr. CF8	1
5	GLAND	ASTM A351 Gr. CF8	1
6	GLAND PACKING	PTFE	1
7	BONNET	ASTM A351 Gr. CF8	1
8	GASKET	PTFE	1
9	BODY	ASTM A351 Gr. CF8	1
10	DISC	ASTM A351 Gr. CF8	1

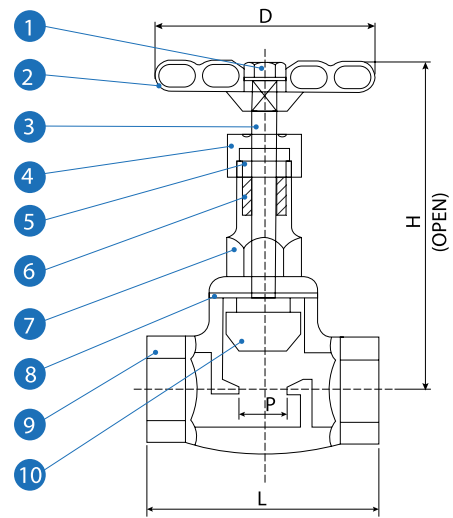

DIMENSIONS (mm)

SIZE	P	L	H (open)	D	CV FACTOR	WEIGHT (Kg)
1/2"	12	66.0	95	70.0	19	0.42
3/4"	15	68.5	99	70.0	37	0.46
1"	20	78.3	102	76.5	64	0.62
1 1/4"	25	86.0	126	103.5	103	1.05
1 1/2"	33	98.0	136	103.5	143	1.40
2"	40	110.5	155	121.0	360	2.10

PRESSURE TEMPERATURE RATINGS

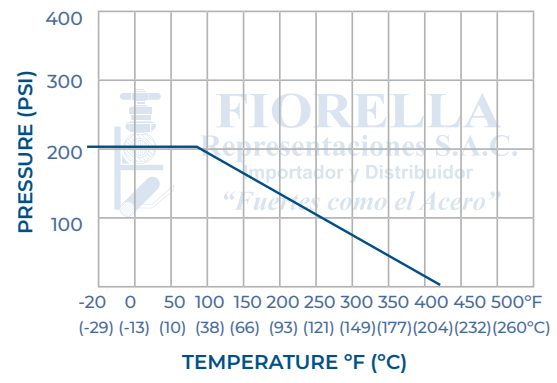

Fiorella Representaciones S.A.C. Importador y distribuidor autorizado de válvulas SUN en territorio latinoamericano.

* Note : Dimensions, design and materials are subject to change without notice.

MAC - MMXXI