



\* Reference photo

## DESIGN FEATURES:

Pressure rating: 200 PSIG (non-shock)  
 Steam rating: 150 PSI WSP  
 Investment cast body & cap  
 Screwed cap  
 Swing type disc  
 Threaded end NPT ANSI/ASME B1.20.1  
 Test standard: API 598

## MATERIAL LIST

	PART NAME	MATERIAL	QTY.
1	BODY	ASTM A351 Gr. CF8M	1
2	CAP	ASTM A351 Gr. CF8M	1
3	DISC	ASTM A351 Gr. CF8M	1
4	HINGE PIN	SS316	1
5	GASKET	PTFE	1
6	PLUG	SS316	1

## DIMENSIONS (mm)

SIZE	A	L	H	CV FACTOR	WEIGHT (Kg)
1/2"	15	66.0	46	30	0.330
3/4"	20	81.0	54	37	0.530
1"	25	91.0	60	54	0.745
1 1/4"	32	106.5	72	103	1.042
1 1/2"	40	121.0	75	143	1.590
2"	50	142.0	82	360	2.275
2 1/2"	65	159.0	30	440	3.80
3"	80	190.0	104	520	5.90
4"	100	235	133.3	-	16.80

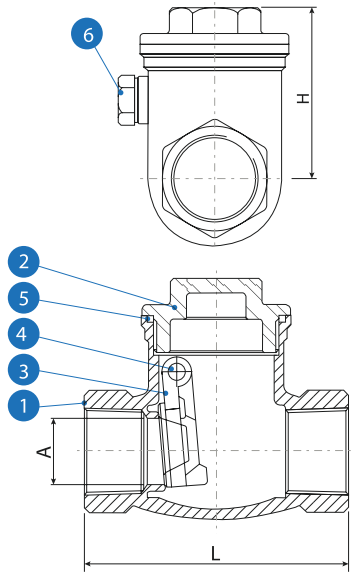

## PRESSURE TEMPERATURE RATINGS

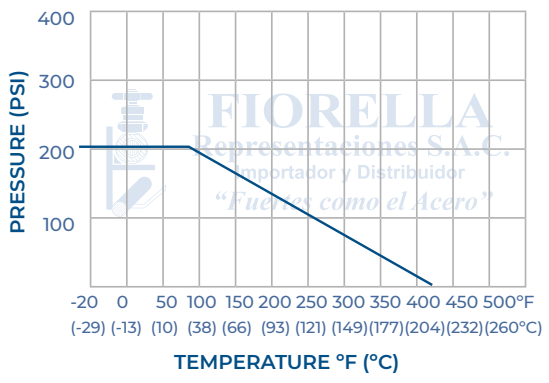

Fiorella Representaciones S.A.C. Importador y distribuidor autorizado de válvulas SUN en territorio latinoamericano.

\* Note : Dimensions, design and materials are subject to change without notice.

MAC EDITIONS - MMXXIII