

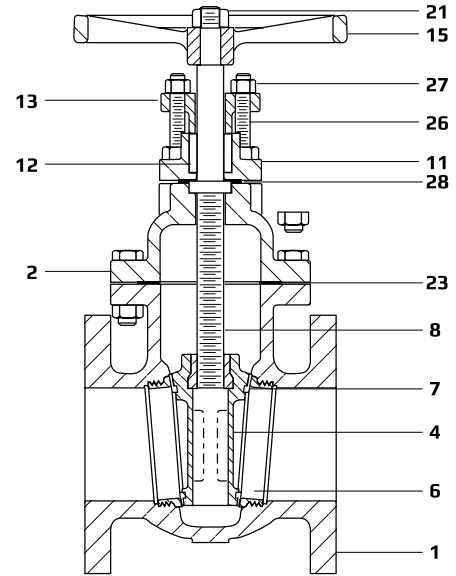

* Reference photo

Standar Design MSS SP-70, Type 1
Phonographic face flange
Non Rising Stem



MATERIALS

	PART NAME	MATERIAL
1	BODY	Cast Iron ASTM A125 Class D
2	BONNET	Cast Iron ASTM A126 Class B
4	DISC	(2"-3") Bronze ASTM B584 C84400 (4"-12") Cast Iron ASTM A126 Class B
6	SEAT RING	Bronze ASMT B584 C84400
7	DISC RING	Bronze ASMT B584 C84400
8	STEM	Stainless Steel 410
11	STUFFING BOX	(2"-8") Ductile Iron ASTM A536 Gr. 65-45-12 (10"-12") Cast Iron ASTM A126 Class B
12	PACKING	Braided Flexible Graphite with Corrosion inhibitor
13	GLANDE FLANGE	Ductile Iron ASTM A536 Gr. 65-45-12
14	GLAND	(10"-12") Bronze ASTM B584 C84400
15	HANDWHEEL	Ductile Iron ASTM A536 Gr. 65-45-12
21	HANDWHELL NUT	Carbon Steel ASTM A536 Gr. A
23	BONNET GASKET	Aramid Fibers with SBR Binder
24	BONNET BOLT	Carbon Steel ASTM A307 Gr. B
25	BONNET BOLT NUT	Carbon Steel ASTM A563 Gr. A
26	GLAND BOLT	Carbon Steel ASTM A307 Gr. B
27	GLAN BOLT NUT	Carbon Steel ASTM A563 Gr. A
28	STUFFING BOX GASKET	Aramid Fibers with SBR Binder
34	STUFFING BOX BOLT	Carbon Steel ASTM A307 Gr. B
35	STUFFING BOX BOLT NUT	Carbon Steel ASTM A307 Gr. B
55	GLAND FOLLOWER	(10"-12") Ductile Iron ASTM A536 Gr. 65-45-12

Fiorella Representaciones S.A.C.
Importador y distribuidor autorizado de
válvulas HGV para Perú y para su exportación.

DIMENSIONS (mm)

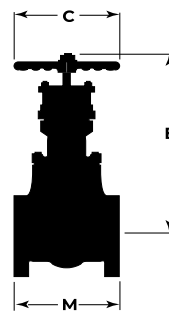

SIZE	B	C	M	WEIGHT (Kg)
2"	287	203	178	16.00
2 1/2"	315	203	191	20.50
3"	337	203	203	23.50
4"	414	254	229	39.00
5"	457	254	254	65.00
6"	526	305	267	69.50
8"	613	356	292	125.00
10"	838	508	330	190.00
12"	927	508	356	267.00

* Note : Dimensions, design and materials are subject to change without notice. Approximate weights.

