



# Gate Cast Steel A216 WCB Class 150

Body and Bonnet Cast Steel A216 WCB  
 Bolted Bonnet  
 Rising Stem OS&Y  
 Design, Manufacture,  
 Test in accordance with API 600  
 Norm Steel Valves: ANSI/ASME B16.34  
 Flange dimensions: ANSI/ASME B16.5 RF  
 Face to Face dimensions: ANSI/ASME B16.10  
 Hydrostatic Testing API 598  
 Diameters: 2" to 24"

\* Certification pending to norm API 600 from American Petroleum Institute

## PRESSURE TEMPERATURE RATINGS

Temperature °F/°C	Pressure worked lbs/inch <sup>2</sup> (PSI)
	Class 150
(-) 20 °F / (-) 29 °C to (+) 100 °F / (+) 38 °C	285
200 °F / 93 °C	260
300 °F / 149 °C	230
400 °F / 204 °C	200
500 °F / 260 °C	170
600 °F / 316 °C	140
650 °F / 343 °C	125
700 °F / 371 °C	110
750 °F / 399 °C	95
800 °F / 427 °C	80
850 °F / 454 °C	65
900 °F / 482 °C	50
950 °F / 510 °C	35
1000 °F / 538 °C	20



\* Reference photo

\* Note : Dimensions, design and materials are subject to change without notice.



# Gate Cast Steel A216 WCB Class 150

## MATERIALS

	PART NAME	MATERIAL
1	BODY	ASTM A216 WCB
2	SEAT RING	ASTM A216 WCB+13% Cr
3	WEDGE	ASTM 216 WCB+13% Cr
4	STEM	SS 410
5	BODY TO BONNET GASKET	304 + GRAPHITE
6	BODY TO BONNET BOLT	ASTM A193 B7
7	BACKSEAT	420
8	PACKING	FLEXIBLE GRAPHITE
9	GLAND FLANGE / GLAND	ASTM A216 WCB / 410
10	EYE / GLAND BOLT	ASTM A193 B7
11	BONNET	ASTM A216 WCB
12	YOQUE / STEM NUT	ZcuAL 10 Fe3
13	HANDWHEEL	ASTM A216 WCB
14	HANDWHEEL NUT	ASTM A194 2H

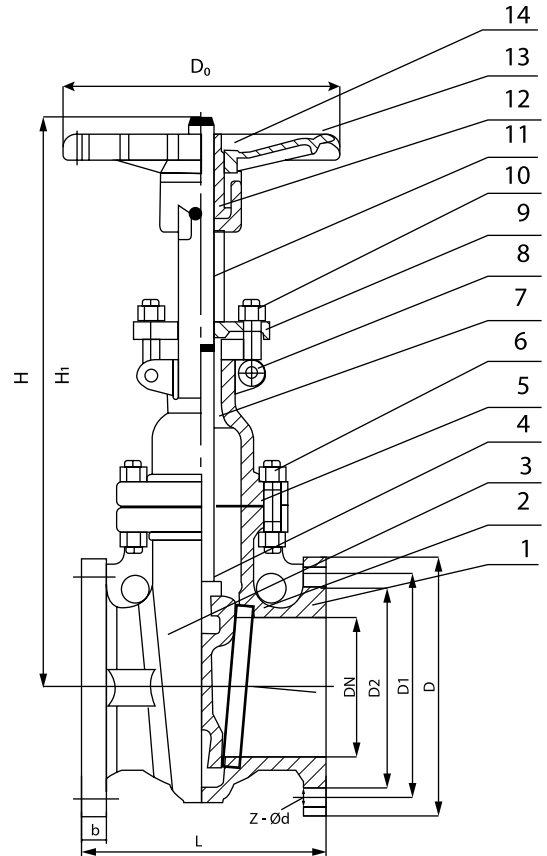

TEST API 598

## DIMENSIONS (mm)

SIZE	L	D	D <sub>1</sub>	D <sub>2</sub>	b	Z-φd	D <sub>0</sub>	H	H <sub>1</sub>	WEIGHT (KG)
2"	178	152	120.5	92	16	4-19	200	342	408	21
2 1/2"	190	178	139.5	105	18	4-19	250	415	492	24
3"	203	190	152.5	127	19	4-19	250	465	552	32
4"	229	229	190.5	157	24	8-19	300	509	624	49
6"	267	279	241.5	216	26	8-22	300	641	804	86
8"	292	343	298.5	270	29	8-22	350	784	1002	135
10"	330	406	352	324	31	12-25	400	922	1186	189
12"	356	483	432	381	32	12-25	500	1096	1412	284
14"	381	533	476	413	35	12-29	600	1207	1568	409
16"	406	597	540	470	37	16-29	650	1350	1752	570
18"	432	635	578	533	40	16-32	650	1472	1943	719
20"	457	699	635	584	43	20-32	650	1630	2143	830
24"	508	813	749.5	692	48	20-35	800	1922	2545	1400

\* Note : Dimensions, design and materials are subject to change without notice.