



GLOBE VALVE FORGED STAINLESS STEEL ASTM A182 CF3M (316L) CLASS 800 NPT OS&Y



MATERIALS

	PART NAME	MATERIAL
1	Body	ASTM A182 CF3M
2	Disc	ASTM A351 CF8M
3	Stem	T316
4	Gasket	SS 316 + GRAPHITE
5	Bonnet	ASTM A182 CF3M
6	Bolt	A193
7	Packing	GRAPHITE
8	Pin	ASTM A276 304
9	Gland	ASTM A182 CF3M
10	Eye Bolt	ASTM A193 B7
11	Gland Flange	ASTM A182 CF3M
12	Nut	A194
13	Yoke Nut	ASTM A276 410
14	Handwheel	ASTM A197
15	Nut	1035 plate Zn

Stem Outside Screw and Yoke (OS&Y)
Threaded NPT ASME B1.20.1
Wall Section ASME B16.34 | Face-to-Face ASME B16.10
Pressure-Temp Ratings ASME B16.34 | Design API 602
Testing API 598

Service Recommendations

It has good resistance to organic acids and salts, sulphuric and sulphurous acids, phosphoric and phosphoric-sulphurichydro fluoric acid mixtures, sulphate and sulphite liquors, sea water and other chloride solutions, sodium hydroxide and steam.

DIMENSIONS

SIZE	L	W	H	d	Weight (kg)
1/2"	2.87	3.94	6.10	0.35	2.196
3/4"	3.15	3.94	6.18	0.47	2.330
1"	3.94	4.92	7.40	0.69	3.782
1 1/4"	4.49	6.30	8.35	0.89	5.200
1 1/2"	5.71	6.30	8.74	1.14	8.200
2"	6.30	7.09	10.39	1.42	12.500

* Dimensions in inches

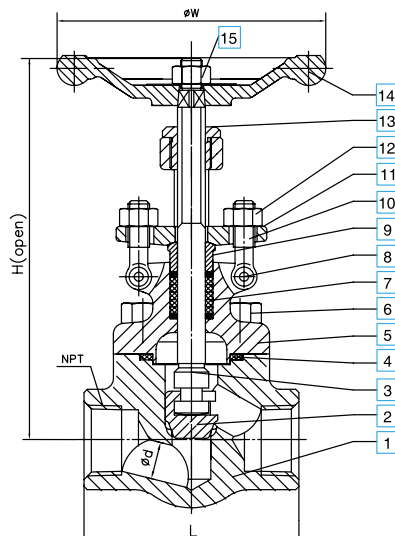

PRESSURE TEMPERATURE

TEMPERATURE		PRESSURE
°F	°C	CLASS 800 (PSIG)
-20 to 100	-29 to 38	1600
200	93	1363
300	149	1217
400	204	1120
500	260	1048
600	316	992
650	349	973
700	371	960
750	399	942
800	427	920
850	454	902

* Note : Dimensions, design and materials are subject to change without notice.