



DOUBLE DISK CHECK WAFER DUCTILE IRON A536 150 PSIG

Body Ductile Iron ASTM A536

Design specs according to: API 594

Flange Connection: ANSI Class 125/150

Maximum working Pressure:
150 PSIG

Disk and shaft stainless steel 316 or 304

Seat elastometric: EPDM

Maximum temperature operation:
EPDM -18°C (0°F) to 110°C (230°F)

Featuring Memoryseal seating
technology

Hidrostatic Test API 598

Diameters: 2" to 24"

NOTE: Soft seated valves are not
recommended for steam service.

* Certification pending to norm API 594 from American Petroleum Institute



* Reference photo

* Note : Dimensions, design and materials are subject to change without notice.



DOUBLE DISK CHECK WAFER DUCTILE IRON A536 150 PSIG

MATERIALS

	PART NAME	MATERIAL
1	BODY	DUCTILE IRON A536
2	SEAL	EPDM
3	DISK	STAINLESS STEEL
4	STEM	STAINLESS STEEL
5	SPRING	STAINLESS STEEL
6	SCREW	CARBON STEEL

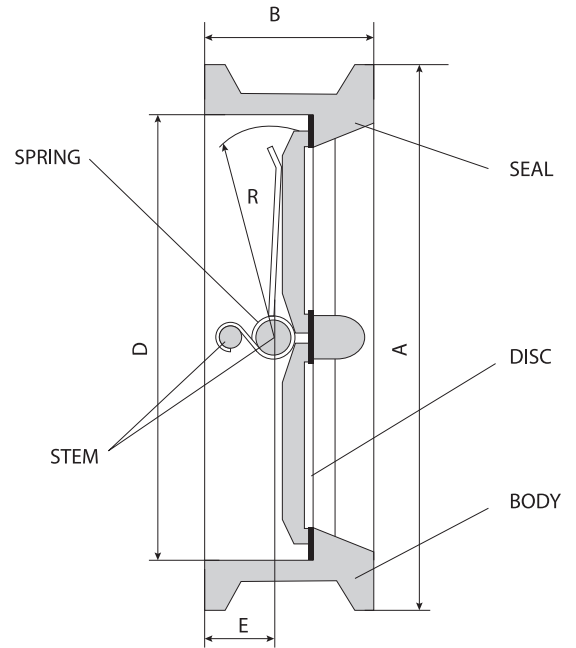

TEST API 598

DIMENSIONS (mm)

SIZE	A	B	R	D	E	WEIGHT (KG)
2"	105	54	28	60	25	1.8
2 1/2"	124	54	35	73	25	2.7
3"	137	57	41	89	25	3.2
4"	175	64	53	114	29	5.4
5"	197	70	64	141	30	6.8
6"	222	76	78	168	19	9
8"	279	95	101	219	40	18
10"	340	108	125	273	40	29
12"	410	143	151	324	56	45
14"	451	184	171	356	94	61
16"	514	191	197	406	89	77
18"	549	203	222	457	86	100
20"	606	213	248	508	90	130
24"	718	222	295	610	87	152

* Note : Dimensions, design and materials are subject to change without notice.